



DE VALK
YACHT BROKERS



DEHLER 41 DS



DE VALK
YACHT BROKERS

KOMMENTARE DES MAKLERS

The Dehler 41DS is a comfortable, fast and safe full weather cruisingyacht. As known from Dehler every design is well thought through and innovative. Resulting in an extremely easy to handle sailingyacht. With incorporated decksaloon with a generous U-shaped sofa and panoramic view.

Marc Weijenberg

TECHNISCHE DATEN

Maße	12.45 x 3.90 x 1.95 (m)	Werft	Dehler Yachtbau
Baujahr	1999	Kabinen	2
Material	GFK	Kojen	6
Motor(en)	1 x Yanmar 4JH3E Diesel	PS/kW	56.00 (PS), 41.16 (kW)
Verkaufspreis	verkauft (MwSt.)	Liegeplatz	beim Verkaufsburo

KONTAKT

Verkaufsbüro	De Valk Sint Annaland	Telefon	+31 166 601 000
Adresse	Koelhuisweg 4 4697 RM Sint Annaland The Netherlands	E-Mail	sintannaland@devalk.nl

HAFTUNGS AUSSCHLUSS

Diese Angaben erfolgen nach bestem Wissen, können jedoch nicht garantiert werden.



ALLGEMEIN

Modell	DEHLER 41 DS
Typ	Segelyacht
Rumpflänge (m)	12,45
Wasserlinienlänge (m)	11,05
Breite (m)	3,90
Tiefgang (m)	1,95
Durchfahrtshöhe (m)	19,50
Stehhöhe (m)	1,95
Baujahr	1999
Lancierung	2001
Werft	Dehler Yachtbau
Land	Deutschland
Entwerfer	Judel & Vrolijk
Gewicht (t)	8,3
Ballast (Ton)	Gusseisen mit Blei 3,3
CE Norm	A
Rumpfmateri al	GFK
Rumpffarbe	Blau
Rumpfform	Rundspant
Art Kiel	Flossen Kiel
Material Aufbauten	GFK
Stossliste	Gummi
Deckmaterial	GFK
Deck Finish	Teak
Deck Finish Aufbauten	gemalt
Pflicht Bedeckung	Teak
Fenster Einfassung	Aluminium
Fenster Material	Perspex
Decksluke	ja
Bullauge	Aluminium



Treibstofftank (Liter)	Edelstahl 160
Trinkwassertank (Liter)	Kunststoff 400
Fäkaelien Tank (Liter)	Edelstahl 50
Fäkaelien Tankablauf	Deck Verbindung + Pumpe
Radsteuerung	Kabelsteuerung Whitlock
Not-Pinne	ja
Weitere Info	Rumpf braucht neue Farbe.

UNTERKUNFT

Kabinen	2
Kojen	6
Innen	Kirsche
Fussboden	Holzabdruck
Decksalon	ja
Standhöhe Salon (m)	1,90
Heizung	Diesel Heißluft Webasto Airtop 5000
Kartentisch	ja
Achterkabine	ja
Dinette zum umbauen	ja
Kombüse	ja
Arbeitsfläche	Kunststoff
Spülbecken	Edelstahl 2x
Herd	Gas Triton 3burner
Ofen	Triton
Kuhlschrank	Coolmatic 12V
Warmwasser System	220V + Motor
Wasserdruck System	elektrisch
Eignerkabine	Doppelbett
Länge Bett (m)	2,05 x 1,50
Kleiderschrank	hängend/Schublad/Regale
Badezimmer	en suite I



Toilet	en suite
Toilette System	handbetrieb
Handwaschbecken	im Badezimmer
Dusche	en suite
Gästekabine 1	Doppelbett
Länge Bett (m)	1,98 x 1,70
Kleiderschrank	hängend/Schublad/Regale
Weitere Info	Ideale Decksalon mit Dinette und panoramische Blick auf die Umgebung.

MASCHINEN

Motoranzahl	1
Marke	Yanmar
Typ	4JH3E
PS	56,00
kW	41,16
Kraftstoffart	Diesel
Installiert im Jahr	1999
Höchstgeschwindigkeit (Kn)	7
Marschgeschwindigkeit (Kn)	6,5
Verbrauch (l/h)	2,5
Motorstunden	1330
Kühlungssystem Motor	indirekte Wärmetauscher
Antrieb	Schraubenwelle
Motor bedienung	Seilzug Kabel
Gewende getriebe	mechanisch
Bugschraube	elektrisch Vetus 50kgf
Exhaust	wassergekühlt
Propeller Typ	Segelstellung Vari-Prop
Propellerblätter	3
Material Propellerwelle	Edelstahl



Propellerwelle schmierung	Wasser
Hand Bilgenpumpe	ja
Elektrische Bilgenpumpe	ja
Elektrische Anlage	12/220V
Starterbatterie	1 x 63amp
Versorgungsbatterie	2 x 210 amp
Bugschraubebatterie	ja
Batterie Monitor	ja
Batterie Ladegerat	Mastervolt Smart 12v-40ah
Landstrom	mit Kabel

NAVIGATION

Kompass	braucht Service Suunto
Elektrisches Kompass	uber Autopilot
Tiefenanzeige	Raymarine ST60
Logge	Raymarine ST60
Windlupe anzeige	Raymarine ST60
Tochter anzeige	beim Kartentisch Raymarine ST60
UKW	Icom IC-M411
Autopilot	Raymarine ST6000+
Ruderwinkel Anzeige	uber Autopilot
GPS	Garmin 128
Plotter	Raytheon A50
Navtex	Nasa
Elektronische Kart(en)	keine elektr. Karte
Navigation Beleuchtung	ja

AUSRÜSTUNG

Feste Fenster	ja
Spritzverdek	ja
Kuchenbude	ja



Cockpit Polster	ja
Cockpit Tisch	ja
Badeplattform	ja
Badeleiter	Edelstahl
Bugtreppe	ja
Anker	ja
Ankerkette	ja
Ankerwinde	elektrisch Lewmar
See Reling	Draht/Seil
Seiten-Einstieg Seereling	ja
Heckkorb	ja
Bugkorb	ja
Rettungsinsel	Container Seatec
Rettungsinsel (Pers)	4
Letzte Wartung Rettungsinsel	04-2019
Leinenschneider	ja
Fenderkissen	ja
Festmacher	ja
Radio-CD Spieler	ja
Lautsprecher im Pflicht	ja
Lautsprecher im Salon	ja
Uhr - Barometer	ja

RIGG

Rig	Fraktionell
Stehendes Gut	Drahtseil
Marke Mast	Sparcraft
Material Mast	Aluminium
Salings	2 sets
Großsegel-Persenning	Dehler Maindrop System
Durchelatted großsegel	Elvstrom



Fock	selbst-wende fock Elvstrom (1999)
Fock I	selbst-wende fock Elvstrom (2003)
Rollreffanlage	Furlex 300S
Genua-Persenning	ja
Gennaker	mit Bergschlauch Elvstrom
Selbstwende Anlage	ja
Reff Vorrichtung	Schnell-1-Lein-Reffsystem
Achterstag Spanner	Talje
Baumniederhohler	Talje Easy-Kick II
Primare Schot Winschen	Elektrisch 2 x Harken 44 EST
Multifunktional Winschen	1x Lewmar 30AST
Spi-Baum	Aluminium



DEHLER 41 DS



DEHLER 41 DS



DEHLER 41 DS

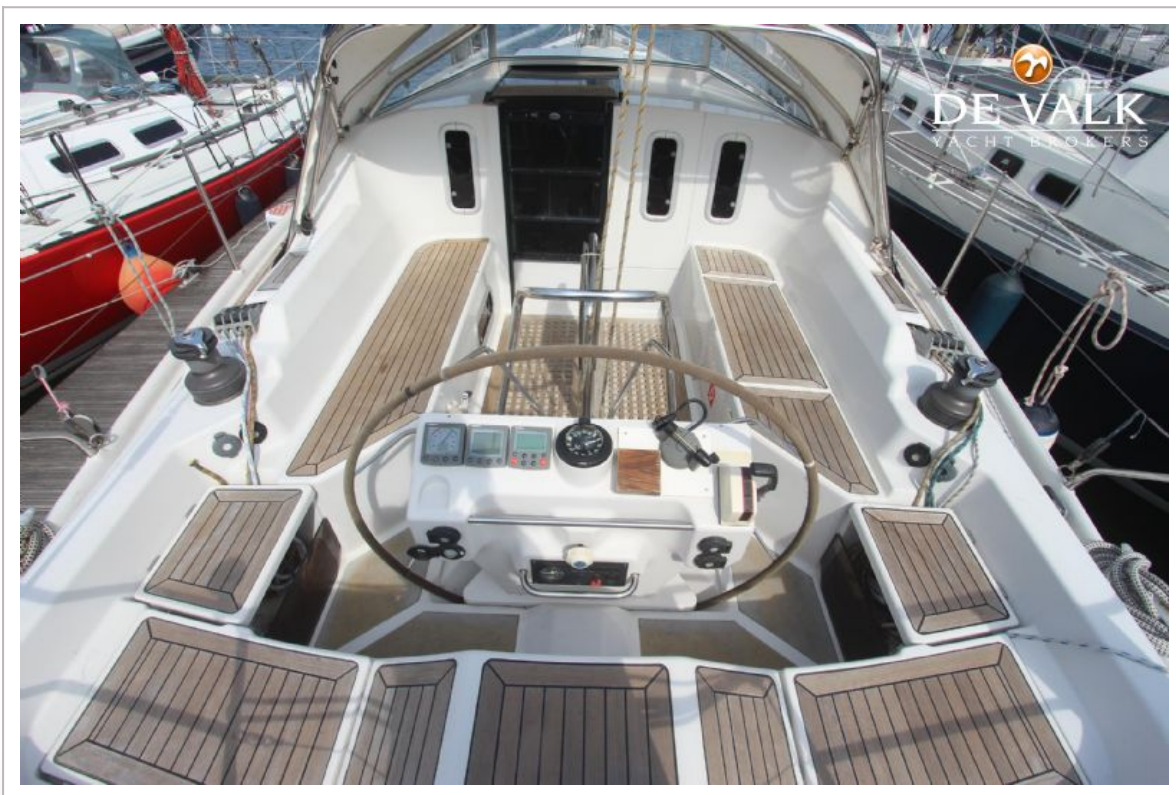

DEHLER 41 DS

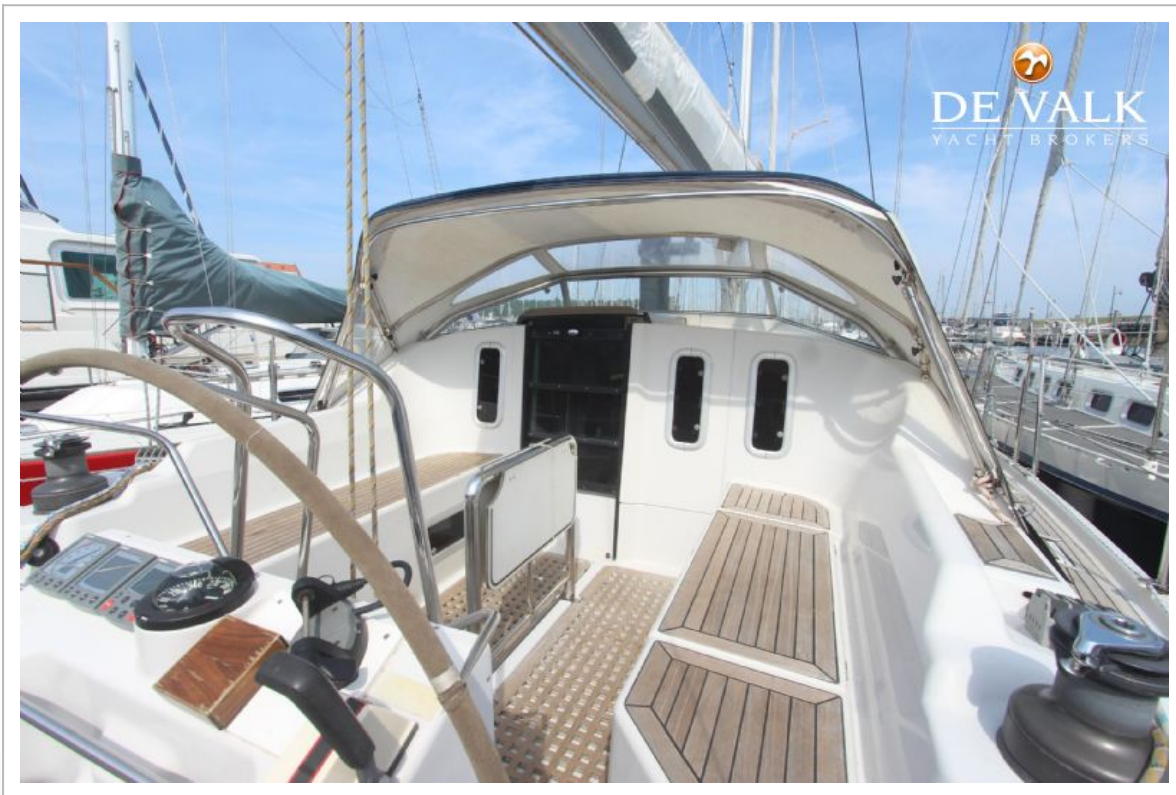

DEHLER 41 DS



DEHLER 41 DS



DEHLER 41 DS



DEHLER 41 DS



DEHLER 41 DS



DEHLER 41 DS



DEHLER 41 DS



DEHLER 41 DS

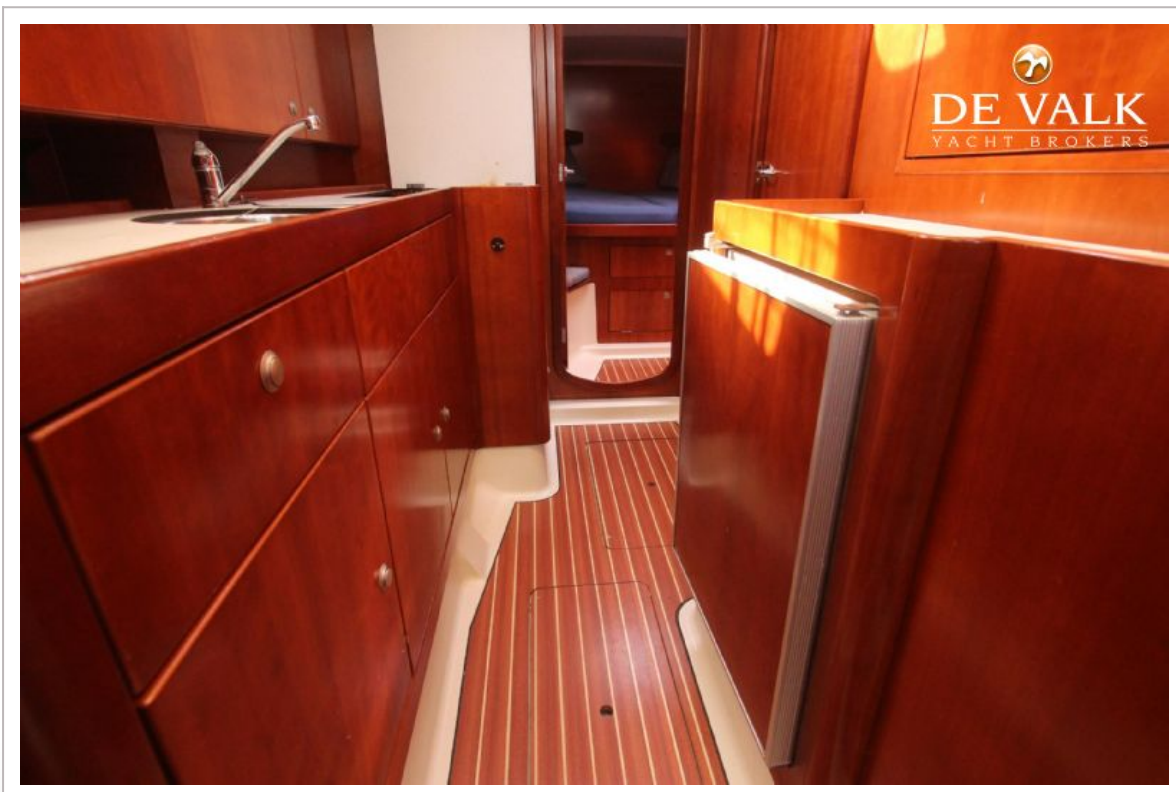

DEHLER 41 DS



DEHLER 41 DS

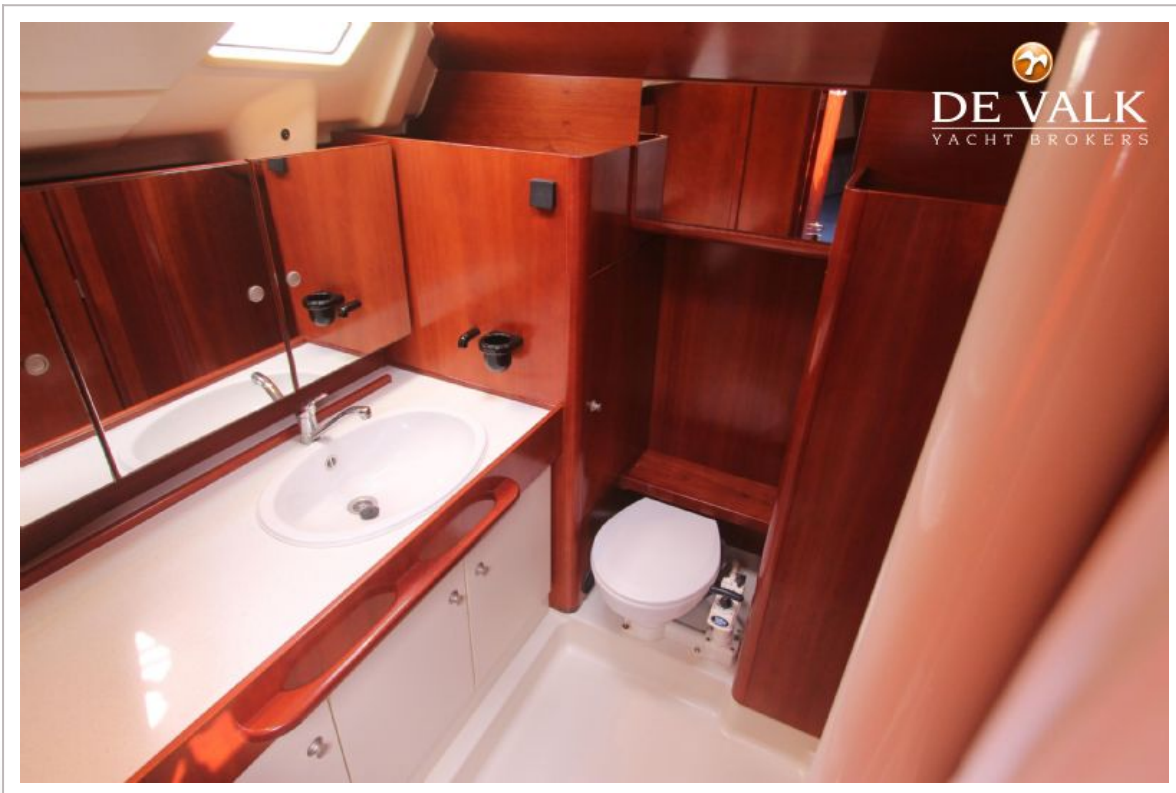

DEHLER 41 DS

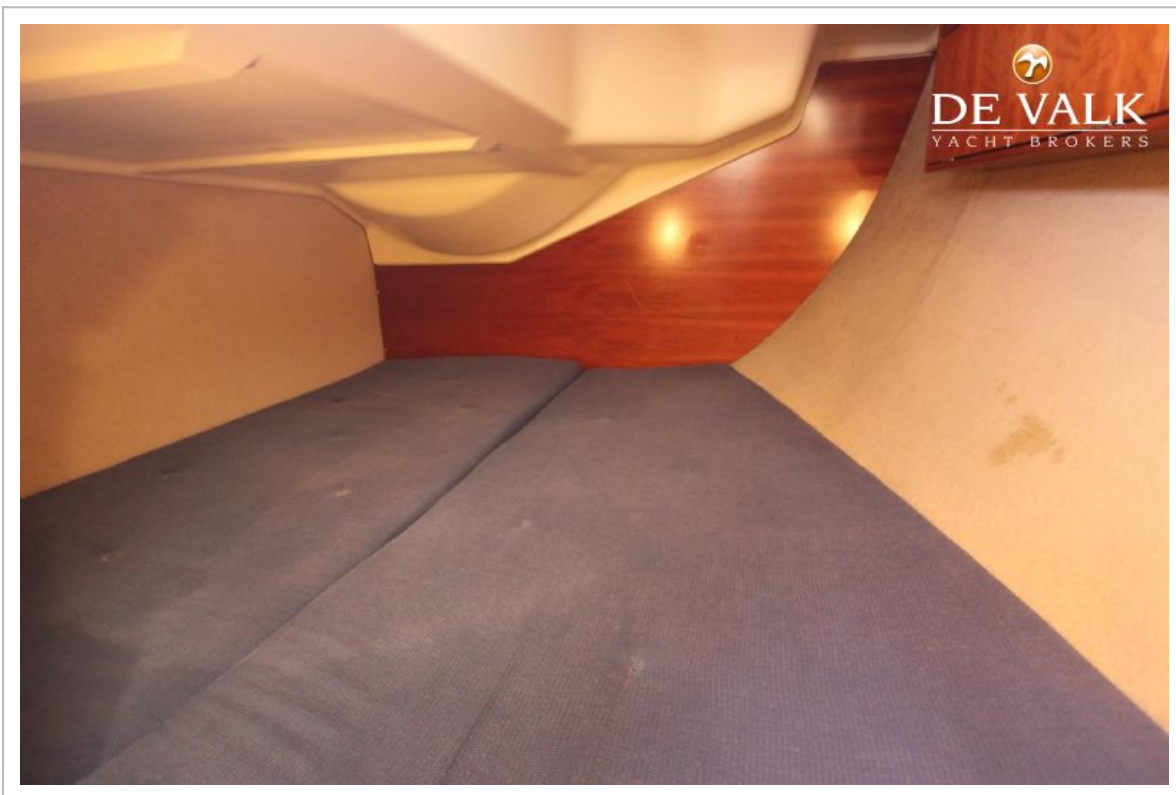

DEHLER 41 DS

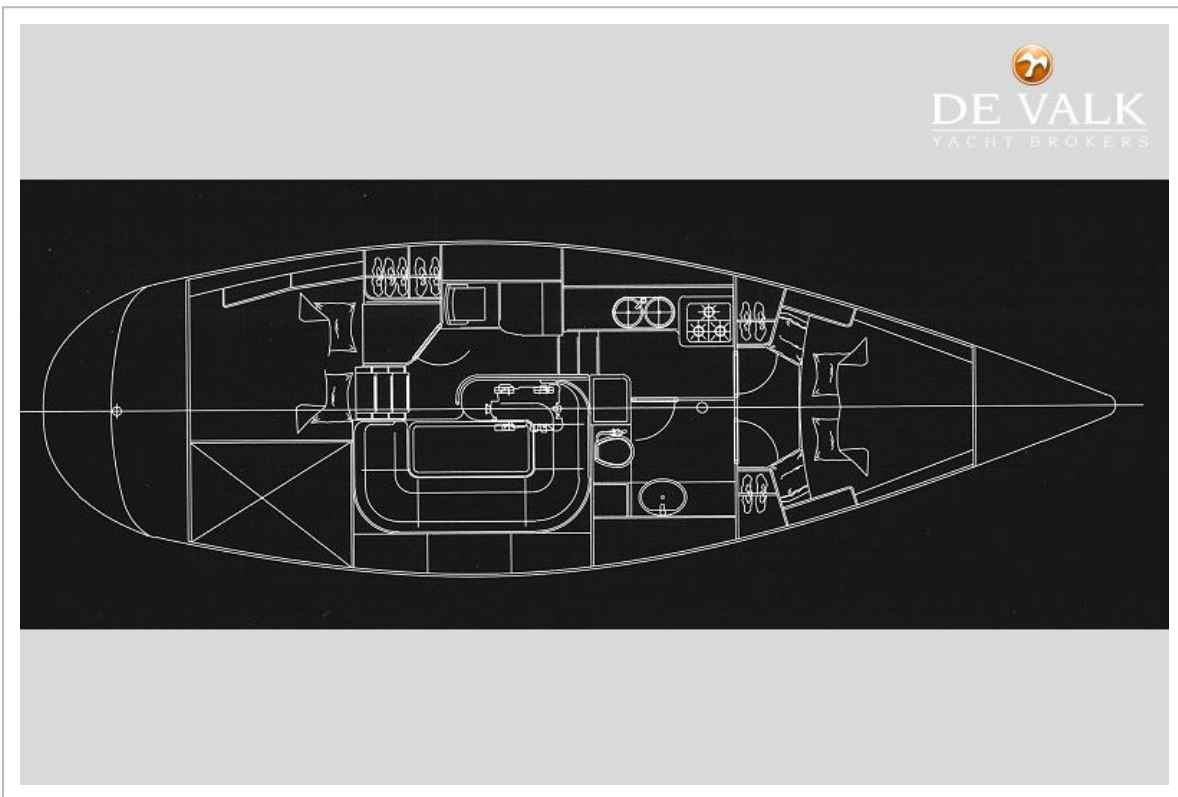

DEHLER 41 DS



DEHLER 41 DS

